

## PROBLEMS WITH REINFORCED CONCRETE INDUSTRIAL FLOORS WITH REGARD TO SUBSOIL SWELLING

JAN PRUŠKA<sup>a,\*</sup>, MIROSLAV ŠEDIVÝ<sup>b</sup>, VOJTĚCH ANDERLE<sup>c</sup>

<sup>a</sup> Czech Technical University in Prague, Faculty of Civil Engineering, Thákurova 7, 166 29 Prague 6 – Dejvice, Czech Republic

<sup>b</sup> GeoTec-GS, a.s., Chmelová 2920/6, 106 00 Praha 10, Czech Republic

<sup>c</sup> Czech Technical University in Prague, Faculty of Civil Engineering, Thákurova 7, 166 29 Prague 6 – Dejvice, Czech Republic

\* corresponding author: Jan.Pruska@cvut.cz

**ABSTRACT.** Most of the problems associated with open cracks in reinforced concrete industrial floors do not arise from technological indiscipline in the execution or exceeding the permitted floor load, but from the geotechnical profile beneath the floor. In the presence of swelling soil in the subsoil, the floors can then be shifted upwards by centimeters and create open cracks. This article describes regression relationships for the prediction of swelling pressure and deformation of reinforced concrete industrial floors based on indirect measurements. These relationships were obtained by evaluating a large database of measurements carried out by the company GeoTec-GS and the Czech Technical University in Prague using neural networks, multiple correlation, regression analysis, and sensitivity analysis. The article also presents the actual classification of the risk of surface damage of reinforced concrete floors due to swelling of the subsoil and an example of its application is given.

**KEYWORDS:** Swelling of clays, indirect prediction of swelling, concrete floors.

### 1. INTRODUCTION

Swelling of soils is a process during which the soil increases its volume or generates swelling pressures, thus causing serious problems on the construction sites where these soils exhibiting variability of volume are located in the subgrade. This process can exist only when the swelling soil can absorb water (or only moisture) from its surroundings. It means that swelling continues until the diffuse double layer is fully formed. Volumetric changes are indirectly dependent on the sorption capacity of clayey soils, which reaches the highest values in the cases of soils rich in montmorillonite and illite. In the Czech Republic, swelling is most frequently encountered in Cypris clay in the Sokolov Basin, very intensely in tuffitic clays, claystone, and also in cretaceous marble. Swelling is a spatial problem, which means that it proceeds omni-directionally, similarly to the effect of hydrostatic pressure.

In recent years, new industrial and storage halls have been built in many locations. The geotechnical survey for each new building is generally focused on the condition of the subsoil with respect to the foundation of the building. In the case of the above-mentioned constructions, it is therefore mainly for the design of pile foundations. For slab foundation methods for these buildings, it is often just a matter of making sure that the basic requirements are met. In addition, surveys are carried out in a very cost-effective manner as investors seek to minimise costs. Therefore, the geotechnical profile immediately under

the future floor is usually not surveyed. In the presence of swelling soils in the subsoil, the floors can be shifted upwards by centimeters and open cracks may form after the work has been carried out. The most frequent failure of floors due to swelling occurs inside the building near the outer cladding of the hall [1, 2]. Rainwater runs down the building envelope and soaks under the floor structure where it saturates the subsoils. The increase in soil moisture under the floor construction then causes volumetric changes in the soil under the floor slab. Their magnitude depends on the swelling pressure and the strength of the floor slab involved in the swelling process [3].

If the effect of swelling was not taken into account during the design of the floor, it must be determined in practice to identify whether the resulting deformations are technically significant for the building for a quick estimation, in addition to the prediction relations for determining the swelling pressure and deformations of wire concrete floors. This article also provides a purposeful classification of the risk of failure of wire concrete floors due to subgrade swelling.

### 2. THE MOST COMMON DAMAGES OF WIRE-CONCRETE FLOORS

Damage of reinforced concrete floors is most often presented by the formation and development of cracks. It should be noted that reinforced concrete is plain concrete. Here it is good to remember that a crack in concrete is natural and inevitable. Any cement bonded to the aggregate during maturation (drying, cooling)



FIGURE 1. Cracks in the reinforced concrete floor of the hall in the corner near the cladding.

exhibits free shrinkage. If this process is limited, stress will increase in the concrete and a crack will appear when the tensile strength is exceeded [4]. Cracks are divided into nonstatic and structural.

From a geotechnical point of view, we are interested in structural cracks that are related to the formation under the floor slab. The loads transmitted by the floor slab do not only act under the slab itself but also spread into the underlying layers, and a low bearing soil layer can thus result in a deformation of the floor or its failure. In the presence of swelling soil in the subsoil, the floors can also be shifted by centimeters and open cracks can form. These are most evident along the cladding of the halls on the inside of the building. Figure 1 and 2 show an example of cracks in a reinforced concrete floor a few weeks after handing over the building to the user. The view in Figure 3 is to the centre of the sloped car park. The hall where the floor failure occurred is on the right of the picture. If you look carefully, you can also see the bulging paving in the line of the car park area (centre of the picture). On the left is the opposite hall, but there were no reported disturbances during the inspection.

### 3. SUBSOILS OF REINFORCED CONCRETE FLOORS

Wire-reinforced concrete floors have a uniform subsoil composition, and the layer thicknesses are designed mainly with regard to the surface load. In industrial halls, high demands are placed on these floors, and therefore higher values of bearing capacity in the subsoil are required. Figure 4 shows a schematic profile of the subfloor. The surface consists of a concrete or wire reinforced concrete slab  $h_{des}$  of the corresponding thickness, usually 150 to 250 mm. Beneath the slab is a structural (substratum) layer of inert fill  $h_{sdr}$ , usually 150 to 250 mm thick. This consists of crushed aggregate, usually of fraction 0/32. If there are cohesive, low-bearing spoils  $h_{sp}$  in the subsoil, the soils are modified by lime or a mixed binder. Beneath the soil modified in this way, swell-prone soils of thickness  $H_{BP}$  'HBP' can be present. The modified soil may

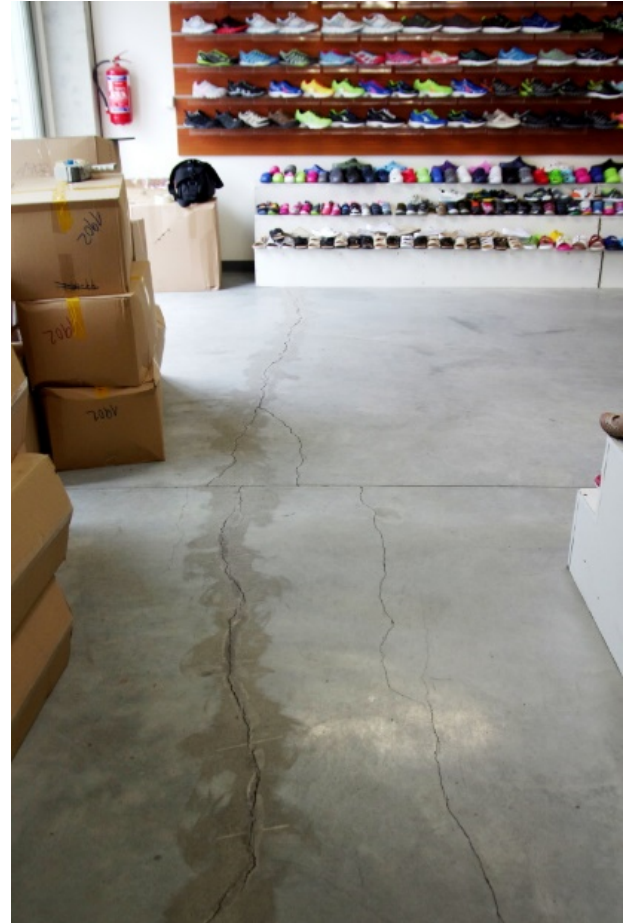

FIGURE 2. Cracks in the reinforced concrete floor of the hall parallel to the cladding. Perpendicular to the cracks is an expansion joint.



FIGURE 3. The parking area between the halls.

also be swell, but is excluded from the swelling process if a mixed binder is used (this is not always the case when lime is used).

Soil modification with lime alone can be risky, as lime alone reduces swelling pressures, but does not completely eliminate them. The most dangerous aspect about using lime alone is that if excessive amounts of lime are applied and the soil is overdried, the swelling effects after the subsequent saturation are even more pronounced [5]. It is therefore preferable

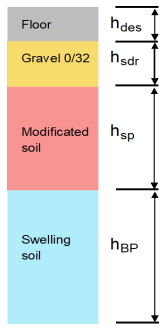

FIGURE 4. Schematic profile of the reinforced concrete floor substrate.

to use a mixed binder, usually a 50% + 50% lime and cement by volume. The amount of mixed binder should be 2% or more by weight. Cement completely suppresses the swelling process in the soil. The free swelling is practically zero during the aging and after submerging the sample in water for the sample of the soil with mixed adhesive at CBR test. The same applies to cement stabilisation. Sometimes the soil has a low initial moisture content. Then, after dosing 2% of the mixed binder, it is necessary to add more water to the cutter drum. But it is also necessary to supply water to the stabilised soil, which is often neglected. And the volume of this water can reach 80 to 100 litres per square metre. In many cases the contractor and especially the investor are of the opinion that if the initial bearing capacity (equivalent deformability modulus) of the subsoil is high, it is not necessary to modify (improve) the soil to ensure the required bearing capacity. This is of course true, but there is often a risk of major problems immediately after the construction. The more load-bearing the soil in the subsoil is, the lower is its moisture content and the more drastic the signs of swelling are, if the soil has a significant swelling potential. The swelling potential should be monitored from the moisture content of shrinkage.

### 3.1. DETERMINING THE SUBGRADE STIFFNESS OF THE REINFORCED CONCRETE FLOORS

Determining the stiffness  $K$  of the subgrade for the case where there is only one non-swelling (resisting) layer above the swelling layer is a trivial task, based on the strain versus force ratio. For the resistance swelling test, these are: dynamometer deformation  $\Delta_h$  and swelling pressure  $\sigma_b$ . The stiffness of the  $K$  layer (in mm/MN) is then expressed by the equation:

$$K = \frac{\Delta_h}{0.001 \cdot \sigma_b \cdot S}, \quad (1)$$

where the deformation of the layer  $\Delta_h$  (in mm) is given by the relation:

$$\Delta_h = \frac{\sigma_z}{E_{def}} \cdot h. \quad (2)$$

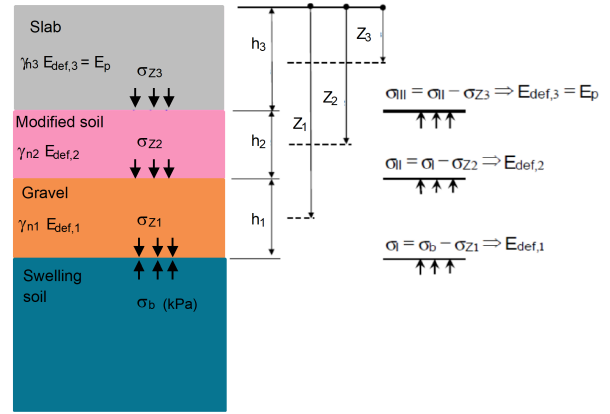

FIGURE 5. Schematic of resisting (inert) positions above the swelling layer.

In contrast to a dynamometer, where there is a linear dependence of “strain – force”, this is not the case with soils. Therefore, the value of the modulus of elasticity must correspond to the stress difference “swelling pressure  $\sigma_b$  – stress at the base of the resisting layer from its weight  $\sigma_z$ ”.

In practice, however, a layered substrate of reinforced concrete floors is common, which must be taken into account when determining stiffness. When describing the determination of the stiffness  $K$  of the profile shown in Figure 4, for the sake of simplicity, we omit the modified soil with a mixed binder with a thickness of  $h_{sp}$  (approx. 45–50 cm) – see Figure 5.

The geostatic stress (in kPa) acting on the base of the  $i$ -th layer is:

$$\sigma_{z1} = \gamma_{n1} \cdot h_1 + \gamma_{n2} \cdot h_2 + \gamma_{n3} \cdot h_3, \quad (3)$$

$$\sigma_{z2} = \gamma_{n2} \cdot h_2 + \gamma_{n3} \cdot h_3, \quad (4)$$

$$\sigma_{z3} = \gamma_{n3} \cdot h_3. \quad (5)$$

The values of the partial moduli of transformation for each inert layer (position) in the overburden of the swelling layer are determined as follows:

A. Lower inert layer – the geostatic tension  $\sigma_{z1}$  is subtracted from the swelling pressure  $\sigma_b$ . The result is the stress value  $\sigma_I$  in kPa (the value is the stress range for determining the deformability modulus  $E_{def,1}$ ):

$$\sigma_I = \sigma_b - \sigma_{z1}. \quad (6)$$

B. Middle inert layer – the geostatic tension  $\sigma_{z2}$  is subtracted from the swelling pressure  $\sigma_I$ . The result is the stress value  $\sigma_{II}$  in kPa (the value is the stress range for determining the deformability modulus  $E_{def,2}$ ):

$$\sigma_{II} = \sigma_I - \sigma_{z2}. \quad (7)$$

C. Top inert layer (CB cover) – the geostatic tension  $\sigma_{z3}$  is subtracted from the swelling pressure  $\sigma_{II}$ . The result is the stress value  $\sigma_{III}$  (in kPa)

$$\sigma_{III} = \sigma_{II} - \sigma_{z3}. \quad (8)$$

The  $\sigma_{III}$  value is the stress range for determining the deformability modulus  $E_{def,3}$ . It should be noted here that this last procedure is used for fill. However, it is not relevant for high-stiffness concrete cover and can be omitted here. The characteristic value of the deformability modulus  $E_{def,ch}$  (in kPa) is determined by the weighted average:

$$E_{def,ch} = \frac{E_{def,1}h_1z_1 + E_{def,2}h_2z_2 + E_{def,3}h_3z_3}{h_1z_1 + h_2z_2 + h_3z_3}. \quad (9)$$

The value of the deformability modulus  $E_{def,ch}$  is inserted into Relation 2 and then into Relation 1 for the stiffness of the layer  $K$ . The resulting value  $K$  is then introduced into the prediction relations for the swelling pressure, and deformation of the wire reinforced concrete floor.

#### 4. PREDICTION OF SWELLING PROCESSES

Methods for determining the swelling potential of the soil can be divided into the following groups:

*Mineralogical identification* – the mineralogical composition has a considerable influence on the swelling of soils and is therefore important for the description of the swelling potential and the soils themselves, e.g. [6–9]. However, from the point of view of geotechnicians and engineering geologists, mineralogical identification methods are uneconomical and impractical.

*Direct measurement of swelling soils* – multiple methods are used here and generally require the use of special equipment. One of the first direct methods was published by Alpan [10], however the most widespread is the measurement of swelling potential under different conditions using an oedometer [11–13]. Kayabali and Demir described the comparison of direct and indirect methods [14].

*Engineering-geological and special maps* are the basic guide for identifying swelling soils (e.g. [15, 16]). Their form can vary greatly depending on the size of the area, the details of the division or focus (risk for foundations construction, raw materials searching). In addition to the scale and details of the division, an important aspect in the map creation is the chosen criteria defining the individual sub-areas. In 2017, as a part of project TA04021261 [17], a special engineering-geological map of soil swelling potential for the area

of the northern and western Bohemia parts (scale 1:50 000) was created. This map is a good source for initial information about the properties of soils in terms of swelling potential that can be expected in places of a planned construction.

*Indirect methods* are mainly based on the results of index tests, moisture, grain size, bulk density, and consistency limits. In the case of indirect measurements, the main advantage is the possibility of using simple laboratory tests or simply knowing the basic properties. Holtz and Gibbs in 1956 determined the swelling potential based on the plasticity number and moisture of the liquid limit [18]. Their empirical sector chart was supplemented in 1981 with areas of the selected clay minerals occurrence [19]. Many empirical graphs showing the expected level of soil swelling susceptibility can be found in the literature [20–23]. In general, however, none is universally valid for all soils or locations. With the computer technology development and using methods such as nonlinear regression, neural networks, correlation analysis, regression analysis, and sensitivity analysis, the original empirical relationships based on indirect measurements were supplemented by other variables. The advantage of using these new indirect methods is also the weight determination of individual parameters and the assessment of the reliability of the derived relationships.

#### 4.1. PREDICTION OF SWELLING PRESSURE AND DEFORMATIONS OF REINFORCED CONCRETE FLOORS

Prediction relationships for quantifying swelling pressures were obtained by evaluating an extensive database of measurements carried out in the Czech and Slovak Republics (clays in Cypris Formation, tuffic clays, siltstones, chalk shale, etc) by company GeoTecGS, a.s. and Czech Technical University in Prague using neural networks, multiple correlations, regression analysis, and sensitivity analysis with the professional statistical program QCExpert [24]. When using neural networks, we can freely choose dependent and independent variables. This can be seen from Figure 1, where there is one dependent value of  $\sigma$  and five (if we consider  $W_K - W_n$  as one variable), or six independent variables (regressors)  $K, W_K, W_n, D_{05}, I_P$  and  $I_A$ .

The following material characteristics of the soil available from laboratory tests were monitored for the prediction of swelling: moisture content at the liquid limit  $W_L$ , moisture content at the plasticity limit  $W_P$ , percentage of grains with a size of 0.002 mm ( $D_{002}$ ), percentage of grains above 0.5 mm ( $D_{05}$ ), calcium carbonate content  $V_{CA}$ , and then the value of the initial moisture (immediate, initial moisture content)  $W_n$ , which is the state variable and the final moisture  $W_k$ . The final moisture content  $W_k$  is the moisture content at which the swelling process is completed for the given material characteristics (if the initial moisture content  $W_n$  is greater than the final moisture

Symbol	Influence	Description
$\sigma_b$	20 %	swelling pressure
$h_{des}$	4 %	thickness of reinforced concrete slab
$f_{tc}$	32 %	cubic strength of concrete
$h_{sdr}$	21 %	thickness of the gravel base layer 0/32
$h_{sp}$	7 %	thickness of the soil modified with a mixed binder under the base layer of gravel
$h_{bp}$	17 %	thickness of the soil involved in the swelling in the subgrade (under the base layer or under the position of the soil, modified with a mixed binder)

TABLE 1. The influence of individual predictors on floor surface deformation.

Symbol	Influence	Description
$\sigma_b$	20 %	swelling pressure
$h_{des}$	5.78 %	thickness of reinforced concrete slab
$f_{tc}$	50.33 %	cubic strength of concrete
$h_{sdr}$	32.67 %	thickness of the gravel base layer 0/32
$h_{sp}$	11.21 %	thickness of the soil modified with a mixed binder under the base layer of gravel

TABLE 2. Percentage effect on floor surface deformation for resistors only.

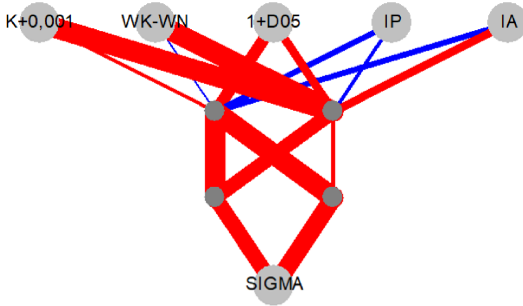

FIGURE 6. Example of graphical neural network output for 5 regressors and 1 explained variable sigma.

content  $W_k$  swelling does not occur) and is determined from the prediction:

$$W_K = (K + 0.001)^{0.0025} \cdot (W_L + I_P)^{0.774} \cdot (1 + D_{05})^{-0.114} \cdot (1 + V_{CA})^{-0.1041}. \quad (10)$$

Prediction of swelling pressure  $\sigma_b$  (kPa):

$$\sigma_b = (K + 0.001)^{-0.048} \cdot (W_K - W_n)^{0.101} \cdot I_P^{1.443} \cdot I_A^{1.757} \cdot (1 + D_{05})^{-0.262}. \quad (11)$$

The  $D_{05}$  value in Relation 10 and 11 is the proportion of inert (non-swelling) grains above 0.5 mm. However, there are soils or semi-rocky soils where the fraction above 0.5 mm is not inert and is also swelling (e.g. claystone, siltstone, ...). In this case, the  $D_{05}$  value is set to zero ( $D_{05} = 0$ ).

The value of the maximum lift (deformation) of the concrete surface in millimeters is based on the following relationship:

$$H_{max} = \sigma_b^{1.224} \cdot h_{des}^{-0.209} \cdot f_{tc}^{-1.181} \cdot (1 + h_{sp}^{-0.405}) \cdot h_{bp}^{0.979}. \quad (12)$$

It is, therefore clear that the maximum deformation of the floor surface is described by six variables (predictors), where the swelling pressure SIGMA  $\sigma_b$  and the power of the swelling position  $h_{bp}$  are destabilising influences and the remaining four variables are resistances, i.e. variables that contribute to the stabilisation of the whole process. The sensitivity analysis shows the influence of each predictor on the deformation of the floor surface – see Table 1.

If we convert only the resistances to percentages of influence, then we get the data in Table 2.

In this case, it can be clearly seen that the thickness of the concrete slab has the least influence on the elimination of the swelling deformation process. It is therefore wrong to assume that it is sufficient to increase the slab thickness from, for example, 200 mm to 250 mm, to eliminate the swelling problem.

## 5. RISK CLASSIFICATION OF WIRE REINFORCED CONCRETE SURFACES DUE TO SUBGRADE SWELLING

For a quick estimation of the significance of the inferred deformation of the wire reinforced concrete floor and, if necessary, the need to correct the design and the project documentation, a special purpose classification of the risk of wire reinforced concrete floors due to the swelling of the subsoil was derived [25]. The classification is based on the scoring of six independent variables (predictors). The swelling pressure  $\sigma_b$  and the thickness of the swelling position  $h_{bp}$  are destabilising (the score decreases with their increase), the other four variables (the thickness of the reinforced



Point evaluation													
$\sigma_b$ swelling pressure (kPa)	≤0.10	30	60	100	200	300	400	500	600	700	800	≥900	Sum
point evaluation	19	18	16	10	6	3	1.60	0.70	0.30	0.10	0.06	0	
assigning points					6								6.00
$h_{bp}$ thickness of soil involved in swelling in the subsoil (m)	≤0.10	0.30	0.50	0.80	1.00	1.50	2.00	2.50	3.00	4.00	≥5.00		
point evaluation	17	7	3.50	1.70	1.10	0.80	0.50	0.13	0.10	0.05	0		
assigning points						0.8							0.80
$h_{des}$ thickness of reinforced concrete slab (m)	0.50	0.45	0.35	0.30	0.25	0.20	0.15	0.10					
point evaluation	4.00	3.50	3.00	2.60	2.00	0.80	0.33	0					
assigning points						0.80							0.80
$f_{tc}$ cubic strength of reinforced concrete (MPa)	45	40	35	30	25	20							
point evaluation	31	24	20	17.6	13	6							
assigning points						6							6.00
$h_{sdr}$ thickness of the layer modified with a mixed binder (m)	0.5	0.45	0.4	0.35	0.30	0.25	0.20	0.15	≤0.10				
point evaluation	19.5	14.6	10	6.8	4.6	2.8	1.26	0.4	0				
assigning points							1.26						1.26
$h_{sp}$ thickness of the modified layer (m)	3.0	2.5	2.0	1.5	1.0	0.5	≤0.1						
point evaluation	7.00	5.30	3.50	2.60	1.80	0.90	0						
assigning points					1.80								1.80
Total score												16.66	
Risk classes													
Class	Point range	Possibility of cracking	Risk of destruction – surface lift										
I	> 50	inessential	none										
II	30 - 50	increased	only local and technically insignificant										
III	25 - 30	high	on a larger scale, significant uplifts and the creation of continuous cracks										
IV	< 25	Extreme high	Extreme, fatal deformation of the surface, significant vertical displacements										

FIGURE 7. Risk classification of wire reinforced concrete surfaces due to subgrade swelling.

concrete floor  $h_{des}$ , the cubic strength of the concrete  $f_{tc}$ , the thickness of the underlying gravel layer  $h_{sdr}$ , and the thickness of the layer modified with a mixed binder ( $h_{sp}$ ) contribute to stability of the structural system, i.e. they resist swelling. Intermediate values of the variable  $\sigma_b$  and  $h_{bp}$  can be linearly interpolated. The resulting score then fits into one of the four risk classes (I, II, III and IV) with a verbal rating for the formation of cracks and the risk of floor damage.

It can be seen, for example, that with a swelling pressure  $\sigma_b = 200$  kPa (this pressure represents a load of approx. 20t acting upwards on an area of  $1\text{ m}^2$ ), the thickness of swelling layer  $h_{bp} = 1.5$  m, and a concrete slab thickness  $h_{des} = 0, 20$  m, cubic strength of concrete  $f_{tc} = 20$  MPa, the thickness of the underlying gravel layer  $h_{sdr} = 0.20$  m, and the thickness of the subgrade layer modified with a mixed binder  $h_{sp} = 1.0$  m, the risk of surface damage is “very high”.

## 6. CONCLUSIONS

Industrial floors in factories and warehouses have long been among the most susceptible to failure. A very common cause of such a failure of these floors is the presence of swelling soils in the subsoil, which were not detected by a geotechnical survey. In such a case, these soils are not taken into account in the design. This often results in damage to the floor and its quite expensive repair. Stopping operations in the hall for days or weeks in particular is costly, and in such cases, it is not just tens of thousands of €/€ to replace the floor in the part of the building. However, swelling is

not a never-ending process. When the increasing moisture in the subsoil reaches the final moisture content, the swelling process is complete. It is difficult to know that the entire swelling process is over. Therefore, it is necessary immediately start geodetic works already at a time when deformations (cracks) are macroscopically visible. This guarantees the monitoring of crack development. Furthermore, it is necessary to relate the daily precipitation to monitoring of the development of the cracks. Subsequently, it is possible to assess the damages using the elimination method.

The subsoil can be saturated not only by seepage of rainwater from the surface around the hall, but also by leaks in the water supply line along the building (or even in it), from sewer backfills or leaks in the joints of the rainwater drainage pipes. If the hall is built partly in the cut of the slope and partly on an embankment, the hydrogeological conditions change. Thus groundwater leaks under the hall, that is, where it was not present before the construction. In order to obtain all the necessary information, an adequate scope of the geotechnical survey is also necessary. Since investors and designers often lack the knowledge in this field, these incidents are not rare.

The issue itself is quite extensive and cannot be presented in a few pages. The presented text gives a basic overview of the problem of soil swelling under wire reinforced concrete floors and presents prediction relationships for determining the swelling pressure and deformation of wire concrete industrial floors based on indirect measurements. To quickly determine the risk

of destruction of a wire reinforced concrete floor due to swelling, a classification derived by the authors of the paper is presented, which is mainly for informative purposes.

#### LIST OF SYMBOLS

$D_{002}$	0.002mm grain content [%]
$D_{05}$	0.5mm grain (inert) content [%]
$E_{def, ch}$	deformability modulus of resisting layers [MPa]
$E_{def1, i}$	modulus of elasticity of the given layer [MPa]
$H_{max}$	maximum value of vertical deformation [mm]
$I_A$	index of colloidal activity [-]
$IP$	plasticity number [%]
$K$	soil toughness ( $K = 0$ ) [mm/MN]
$S$	sample (contact) area ( $m^2$ ), assumed 1.0 [ $m^2$ ]
$V_{CA}$	content of calcium carbonate [%]
$W_K$	terminal water content of swelling [%]
$W_L$	water content at liquid limit [%]
$V_n$	initial water content [%]
$V_S$	water content at shrinkage limit (possibly humidity corrected for shrinkage $W_S^*$ ) [%]
$f_{tc}$	cubic strength of reinforced concrete [MPa]
$h$	thickness of resisting layer (position) [m]
$h_i$	thickness of i-th layer [m]
$h_{bp}$	thickness of subsoil soil involved in swelling [m]
$h_{des}$	thickness of reinforced concrete (concrete) slab [m]
$h_{sdr}$	thickness of the underlying gravel layer [m]
$h_{sp}$	thickness of the modified layer [m]
$h_{sdr}$	thickness of the underlying gravel layer [m]
$\Delta h$	layer deformation [mm]
$\sigma_b$	swelling pressure in the layer in the subsoil (with restrained deformation) [kPa]
$\sigma_z$	vertical geostatic stress from the overburden [kPa]

#### ACKNOWLEDGEMENTS

The paper was supported by the grant of CTU in Prague No. SGS21/147/OHK1/3T/11.

#### REFERENCES

- [1] J. Rogers, R. Olshansky. Damage to foundations from expansive soils. *Claims People* **3**(4):1–4, 1985.
- [2] M. Šedivý, J. Pruška. Swelling of soils in practice. *Tunel* (1), 2019.
- [3] S. Kwiecien. Failure of a warehouse floor by subsoil settlement. *MATEC Web of Conferences* **284**:04004, 2019. <https://doi.org/10.1051/mateconf/201928404004>
- [4] J. Dohnálek. Vady průmyslových podlah a možnosti jejich sanace – 1. část, 2021. [2021-01-11]. <https://www.imaterialy.cz>
- [5] E. Vrbová. *Stabilizace zemin*. Master's thesis, CTU in Prague, 2008.
- [6] A. J. Puppala, A. Pedarla, L. R. Hoyos, et al. A semi-empirical swell prediction model formulated from 'clay mineralogy and unsaturated soil' properties. *Engineering Geology* **200**:114–121, 2016. <https://doi.org/10.1016/j.enggeo.2015.12.007>
- [7] A. Sridharan. Engineering Behaviour of Clays: Influence of Mineralogy. In C. DiMaio (ed.), *Chemo-Mechanical Coupling in Clays: From Nano-scale to Engineering Applications*. Routledge, London, 1st edn., 2017. <https://doi.org/10.1201/9781315139289>
- [8] J. Du, A. Zhou, X. Lin, et al. Prediction of swelling pressure of expansive soil using an improved molecular dynamics approach combining diffuse double layer theory. *Applied Clay Science* **203**:105998, 2021. <https://doi.org/10.1016/j.clay.2021.105998>
- [9] B. H. Rao, P. S. Reddy, B. Mohanty. Combined effect of mineralogical and chemical parameters on swelling behaviour of expansive soils. *Scientific Reports* **11**, 2021. <https://doi.org/10.1038/s41598-021-95746-5>
- [10] I. Alpan. An apparatus for measuring the swelling pressure in expansive soil. In *Proceedings of the 4th International Conference on Soil Mechanics & Foundation Engineering*, pp. 3–5. London, 1957.
- [11] H. Elbadry. Simplified reliable prediction method for determining the volume change of expansive soils based on simply physical tests. *HBRC Journal* **13**(3):353–360, 2017. <https://doi.org/10.1016/j.hbrcj.2015.10.001>
- [12] M. Bouassida, S. Manignavy. New approach for characterization and mitigation of the swelling phenomenon. *Frontiers in Built Environment* **8**:836277, 2022. <https://doi.org/10.3389/fbuil.2022.836277>
- [13] Y. I. Mawlood, R. A. Hummadi. Large-scale model swelling potential of expansive soils in comparison with oedometer swelling methods. *Iranian Journal of Science and Technology, Transactions of Civil Engineering* **44**:1283–1293, 2020. <https://doi.org/10.1007/s40996-019-00307-6>
- [14] K. Kayabali, S. Demir. Measurement of swelling pressure: direct method versus indirect methods. *Canadian Geotechnical Journal* **48**, 2011. <https://doi.org/10.1139/T10-074>
- [15] E. Stell, M. Guevara, R. Vargas. Soil swelling potential across Colorado: A digital soil mapping assessment. *Landscape and Urban Planning* **190**:103599, 2019. <https://doi.org/10.1016/j.landurbplan.2019.103599>
- [16] A. S. Muntohar. Prediction and classification of expansive clay soils. In A. A. Al-Rawas, M. F. A. Goosen (eds.), *Expansive Soils*. CRC Press, London, 1st edn., 2006. <https://doi.org/10.1201/9780203968079>
- [17] TA04021261. Výzkumný úkol: Predikce a minimalizace rizik poruch staveb způsobených bobtnáním zemin, certifikovaná metodika, 2017.
- [18] W. G. Holtz, H. J. Gibbs. Engineering properties of expansive clays. In *Transactions of the American Society of Civil Engineers*, pp. 641–679. Reston, VA 20191-4400, 1956.
- [19] R. D. Holtz, W. D. Kovacs. *An Introduction to Geotechnical Engineering*. Prentice Hall, New Jersey, 1981.
- [20] I. Yilmaz. Indirect estimation of the swelling percent and a new classification of soils depending on liquid limit and cation exchange capacity. *Engineering Geology* **85**(3):295–301, 2006. <https://doi.org/10.1016/j.enggeo.2006.02.005>

- [21] F. E. Jalal, M. Iqbal, M. Khan, B. A. Salami. Indirect estimation of swelling pressure of expansive soil: GEP versus MEP modelling. *Advances in Materials Science and Engineering* **85**(3):1827117, 2023. <https://doi.org/10.1155/2023/1827117>
- [22] A. Soltani, M. Azimi, B. C. O'Kelly. A fuzzy classification process for swelling soils. *Transportation Infrastructure Geotechnology* **10**(3):474–487, 2023. <https://doi.org/10.1007/s40515-023-00320-3>
- [23] A. Djellali, A. Houam, B. Saghafi. Indirect estimation of swelling pressure of clayey subgrade under pavement structures. *Arabian Journal for Science and Engineering* **42**:3991–3999, 2017. <https://doi.org/10.1007/s13369-017-2546-7>
- [24] J. Pruška, M. Šedivý. Prediction of soil swelling parameters. In *Procedia Earth and Planetary Science 15: Proceedings of The World Multidisciplinary Earth Science*, pp. 219–224. Elsevier, 2015. <https://doi.org/10.1016/j.proeps.2015.08.052>
- [25] M. Šedivý, J. Pruška. Problematika drátkobetonových podlah s ohledem na bobtnání zemin v podloží. *Stavebnictví* (5):24–28, 2016.