

GEOTECHNICAL ANALYSIS AND REMEDIAL DESIGN OF A POTENTIALLY UNSTABLE CUTTING

Zdenek Siska

Czech Technical University in Prague, Faculty of Civil Engineering, Department of Geotechnics, Prague, Thakurova 7/2077, 166 29, Czech Republic; siskazde@fsv.cvut.cz

ABSTRACT

The article deals with the analysis of a potentially unstable cutting in weak rocks and a design of its remediation. It is described here the collection of information, its interpretation and stability analysis of the cutting, which focuses on deeper than just surface slip surfaces to assess the risk of slope movements with significant safety and economic impact. Based on the results of the evaluation, appropriate remediation measures are proposed.

KEYWORDS

Slope stability, Geological data collection, Structural analysis, Remedial measures

INTRODUCTION

Landslides can be a major geodynamic phenomenon with significant impacts on the environment and human activity. They usually arise when the stability of a slope is disturbed by its own weight, surface overload, inappropriate changes in slope, adverse changes in the water regime, as a result of earthquakes, etc.

Where terrain modification is required, slope movements should be prevented by appropriate design that identifies and evaluates potential risks. If there is already an existing unsatisfactory condition, this is followed by an assessment and design of remediation measures. Both cases should also be accompanied by appropriate monitoring. An example of the use of monitoring and the evaluation of data obtained in this way can be found, for example, here [1].

This article shows on a particular small-scale slope stability issue the usual procedure for evaluation and remedial design.

The area of interest can be seen in Figure 1. It is a cutting made approximately 80 years ago which in its northern part experiences a continuous sliding of material due to surface erosion. There is limited access to the cutting as it is adjacent to an existing structure. The constrained spatial conditions, together with the need for a cost-effective solution, limit to some extent the use of larger and more robust technologies for both exploration and subsequent remediation.

GEOLOGICAL CONDITIONS AND GEOTECHNICAL MODEL

The determination of the geological and geotechnical conditions, including material parameters, was based on in situ inspection, excavated probes, laboratory tests and archival and map materials of the Czech Geological Survey.

Geological conditions

The area of interest is located in the area through which passes a system of tectonic faults called the Blanice Graben, which was formed 305-300 million years ago. The cutting is made in the right bank slope of the valley in which the local brook is situated. The rocks exposed by the cutting

are alternating grey and red colored sandstones (see Figure 2). According to the 1:50 000 geological map [2], these are Upper Carboniferous and Permian in age. The Quaternary cover of the sandstones, according to in situ inspection, consists of sandy silts. According to the mapped slope deformations [3], there are no landslide areas in the area of interest.

The cutting consists of a stable part with healthy sandstone, which is covered with vegetation, and an unstable - exposed part (see Figure 1). The unstable part is the main focus of this paper, as it is identified as potentially the most critical part of the cutting.



Fig. 1 - The cutting with the stable part covered with vegetation and the exposed unstable part



Fig. 2 - A rock sample from the weathered face of the cutting with an interface of grey and red sandstone

Hydrogeological conditions

The water regime in the vicinity of the site of interest is described in an archival survey for the local irrigation reservoir [4]. Here it is noted that the local sandstones have a siliceous cement and very sparse fractures, often filled with surrounding material. Clay and clay shale, which are almost impermeable to water, also occur in the area. The borehole survey indicated only the presence of a shallow groundwater horizon in the alluvial sediments in the local brook inundation. In the boreholes located in the slopes outside the inundation, no water was detected at all. This survey was carried out during periods of heavy rainfall.

An in-situ inspection conducted on 3/2023 during the spring rainy season did not reveal any water discharge from the cutting. Also, a well was found in the very vicinity of the cutting in the brook's inundation area. A steady water level was found here approximately 3 meters below ground level. This is consistent with the above-mentioned archival survey.

Geotechnical cross-section

On the basis of the in-situ inspection and archival documents, a geotechnical profile was made (Figure. (4)3). The slope of the cutting is approximately 60° and the slope of the ground above the cutting is 27° .

The rock in the form of sandstone is overlaid by 2 m of sandy clay. The thickness of this Quaternary cover above the cutting was determined by in situ inspection considering the data in the archive borehole survey as well. Below the base of the cutting, the geotechnical profile took into account the brook inundation area according to the bedrock encountered during the nearby well excavation and also from the archival survey for the local irrigation reservoir [4]. A 0.5 m thick weathered zone was also defined in the face of the cutting representing weathered rock with poorer properties. The groundwater level was set at a depth of 3 m below the base of the cutting.

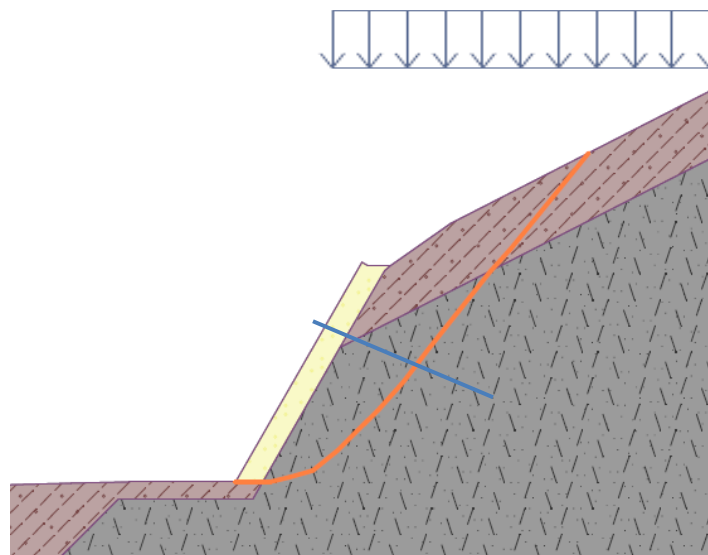

Fig. 3 - Optimized polygonal slip surface with marked snow load and position of extensometer in the upper third of the cutting

Laboratory tests and parameter determination

Sandstone samples were taken from the weathered zone during the in-situ inspection and were subjected to the point load test. Subsequently Mohr-Coulomb shear parameters were estimated using a conversion of the resulting point load index to obtain uniaxial compressive strength

and uniaxial tensile strength which is shown in Figure 4. The whole procedure is in detail explained in [5].

The resulting estimations of the effective angle of inner friction equals 32° and effective cohesion equals 21 kPa. As aforementioned, these parameters relate to the weathered zone. It wasn't possible to obtain rock samples from larger depths under the face of the cutting by hand because of rapid increase in strength of the sandstone. Therefore, these shear parameters represent very conservative lower limit of the solid sandstone capabilities, which can compensate for unknown positions of discontinuities or disintegration into blocks. Shear parameters for the weathered zone itself were chosen to have the same angle of inner friction as the ones estimated for the sandstone, but no cohesion which is supposed to characterize long term weathering. Shear parameters of the overlaying sandy clay were estimated with respect to parameters of the original rock and the parameters reported in the Czechoslovak national standard CSN 73 1001 [6]. The resulting Mohr-Coulomb material Parameters are summarized in Table 1.

Tab. 1 - Estimated effective material parameters for Mohr-Coulomb model of the cutting

Material	ϕ' [°]	c' [kPa]
Sandstone	32	21
Sandy clay	29	12
Weathered zone	32	0

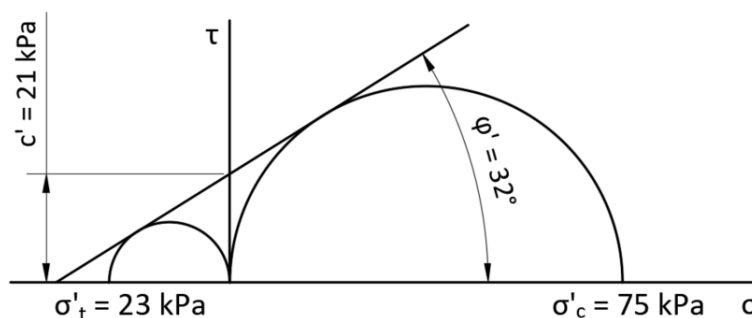

Fig. 4 - Determination of $\phi' = 32^\circ$ and $c' = 21$ kPa based on uniaxial compressive and tensile strength [5]

STRUCTURAL ANALYSIS OF THE CUTTING

The actual slope stability evaluation was performed by the limit equilibrium methods using both the circular and polygonal slip surfaces and their optimization. For this analysis a software GEO 5 was used. The slip surface was prevented from running parallel through the weathered face in order to trace potential slip surfaces within the slope. The shape of the most critical polygonal shear surface can be seen in Figure. 4. The snow load on the slope above the cutting was also considered and its magnitude was determined using a snow map to be $q = 0.64$ kN/m² [7]. Another surface load above the cutting wasn't considered because the area here serves only as a fruit garden and the 27° slope doesn't allow for its another utilization. If these actual conditions changed, the analysis would have to be repeated reflecting a new situation.

The evaluation was carried out both by using the shear strength according to EN 1997-1 [8] using design approach 3 and by determining the factor of safety. According to EN 1997-1 [8], the result of the evaluation is presented in the form of a percentage of utilization of the total shear strength along the shear plane to withstand the resulting active forces acting on the body of the landslide. The factor of safety on the other hand is a ratio between the total shear strength along the shear plane and the resulting active forces acting on the body of the landslide.

The evaluation was made using the Bishop, Sarma, Spencer, Janbu and Morgenstern-Price methods. The minimum permissible degree of stability was determined according to the Czech technical standard CSN 73 6133 [9]. It requires a minimum factor of safety of the cutting in the rocks $FS = 1.3$ when considering the peak effective shear parameters. The results of all the methods are summarized in Table 2. According to these results, the cutting can be declared stable, only with problems caused by surface erosion. These are addressed by the remediation design in the next section.

Tab. 2 - Results of the static slope stability evaluation

Method	Utilization according to CSN EN 1997-1 DA3 (<100 %)	Factor of safety stability FS (>1,3)	Evaluation
Bishop	87,9 %	1,43	Comply
Sarma	85,2 %	1,46	Comply
Spencer	92,2 %	1,35	Comply
Janbu	95,3 %	1,31	Comply
Morgenstern-Price	95,3 %	1,31	Comply

SURFACE EROSION REMEDIATION DESIGN

Since the structural analysis did not identify problems with the stability of the slope, so the remediation design of the cutting may be limited to anti-erosion measures in the form of an anchored lining of its face. This measure is necessary for the part of the cutting visibly degraded by surface erosion, referred to in this text as the 'unstable part' (see Figure 1). It is possible that the part of the cut referred to in this text as 'stable' (see Figure 1), consisting of more solid rock, may not require this measure. However, since the stable part of the cutting is presently covered by climbing vegetation, it is not possible to assess it comprehensively in terms of rock quality, discontinuities, loose blocks of rock, etc. For this reason, and also for the sake of a uniform appearance of the face of the cutting, a single remediation design has been submitted for the entire cutting.

The proposed design consists of gabion lining covering the face of the cutting through the separating geotextile and surface water drainage situated at the crown and at the base of the cutting. The lining is secured by nailing up to the healthier rock (see Figure. 5). The nailed gabion lining system has been evaluated again by structural analysis. The design emphasizes construction using only hand tools with regard to the spatial constraints mentioned above and the need for a cost-effective solution. Other types of lining would be possible as well (e.g. sprayed concrete), but always in combination with nailing for securing its stability.

For verification of the design and the results of the structural analysis, an extensometer placed in the upper third of the cutting is proposed as monitoring. Its length is required to be 4 m to reach safely beyond the possible expected slip surface (see Figure 4). Various types of extensometers are possible to use here ranging from standard rod to FBG extensometers.

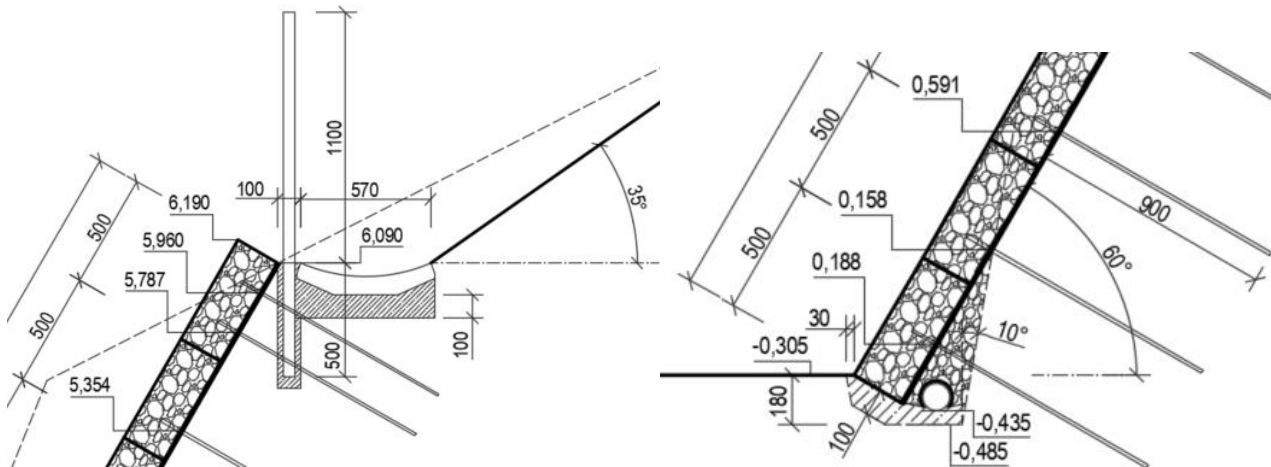

Fig. 5 - Preview of the anti-erosion measure of the face of the cutting - nailed gabion lining; on the left the drained back of the structure at the foot of the slope; on the right the surface drainage of rainwater above the cutting

Nailing of gabion lining

The gabion's back mesh is anchored through the base plates with a nail through the weathered face into the healthier rock. The primary purpose of the nails is horizontal and vertical stabilization of the erosion control lining.

The nails are 1 m long and consist of an M12 threaded stainless steel rod. They are inserted into 30 mm diameter boreholes 900 mm deep filled with cement grout. A 100 mm long nail will therefore protrude from the aligned and cleaned face. Stainless steel is essential when grouting with cement grout. This precludes the use of zinc-coated rods as the hardening cement loses its strength in the presence of zinc [10].

In place of stable rock, it is conditionally possible to use dowels, chemical anchors and other suitable anchoring material of shorter lengths instead of nails. It can be estimated that up to half of the wall area may be involved.

CONCLUSION

In its introduction, the article briefly summarizes typical geotechnical risks associated with slope stability and then shows the usual procedure for solving this problem. Using archival materials and in situ inspection, an introduction to the geology of the site of interest in which the cut is located is demonstrated. With this background and considering the possible risks mentioned in the introduction of the paper, a geotechnical model is developed, and the slope stability is analyzed. According to the results of the analysis, remediation measures are proposed together with recommendations for monitoring.

ACKNOWLEDGEMENTS

This article was supported by internal grant of Czech Technical University in Prague SGS24/081/OHK1/2T/11.

REFERENCES

- [1] Zalesky, J., Capova, K., 2017. Monitoring and Assessment of Remedial Measures in Closed Open Cast Mine. *Advancing Culture of Living with Landslides*, no. 3: 597–605. DOI: 0.1007/978-3-319-53487-9.
- [2] Geologická mapa 1 : 50 000 - indexes, Geologická mapa 1 : 50 000 - doplňky, Geologická mapa 1 : 50 000, Klad listu ZM50. In: *Geovední mapy 1 : 50 000* [online]. Czech Geological Survey [cit. 2024-02-20]. Available from: <https://mapy.geology.cz/geocr50/>
- [3] Mapovane svahove deformace, Registracni zaznamy, Listoklad ZM 10. In: *Svahove deformace* [online]. Prague: Czech Geological Survey [cit. 2024-02-20]. Available from: https://mapy.geology.cz/svahove_nestability/
- [4] Muzik, P. et al., 1981. *Ksely zavlahová nadřz – Predbezny inz. geologicky pruzkum staveniste* (Agroprojekt projektovy a inženýrsky podnik v Praze, Karlovy Vary)
- [5] Siska, Z., 2023. Point Load Test and its Utilisation During the Assessment of a Cutting in Weak Rocks. In: *15. Slovenska Geotechnicka Konferencia*. 151-160 ISBN 978-80-227-5313-5.
- [6] CSN 73 1001. *Zakladani staveb. Zakladova puda pod plosnymi zaklady* Prague: Vydavatelstvi Uradu pro normalizaci a mereni, 1987. 76 p.
- [7] Mapa zatizeni snehem na zemi. In: *Mapa zatizeni snehem na zemi* [online]. Prague: Czech Hydrometeorological Institute [cit. 2024-01-10]. Available from: <https://clima-maps.info/snehovamapa/>
- [8] CSN EN 1997-1. *Eurocode 7: Geotechnical design - Part 1: General rules*. Prague: Czech Standards Institute, 2006. 138 p.
- [9] CSN 73 6133. *Road earthwork - design and execution*. Prague: Czech Standards Institute, 2010. 68 p.
- [10] Pokorny, P., 2012. The influence of galvanized steel on bond strength with concrete. *Koroze a ochrana materialu*, vol. 56, no. 4: 119–135. DOI: 10.2478/v10227-011-0020-9.